

SUMP PUMP CONTROL PANEL



OVERVIEW

Power Assemblies has designed a family of low-cost, high-quality, UL580A Listed control panels for use with sump pumps. With two sizes and multiple options these panels are ready to control pumps with limit switches for the purpose of displacing water. These panels provide a quality solution for water control measures from small to medium load applications. All units are UL Listed and designed for both commercial and industrial use.

Features and Benefits



Flexible design allows for single or dual pump configurations



ANSI-61 gray powder coated 0.075 carbon steel for long life and corrosion resistance



Easy installation and set up



UL508A Listed



Available in 3 Phase 480V or 208V or 1 Phase 120V or 240V



NEMA 4/12 enclosure suitable for wind driven rain and remains undamaged by the external formation of ice on the system



← DUAL PUMP

SINGLE PUMP →



PART NUMBER BUILDER

SPP -

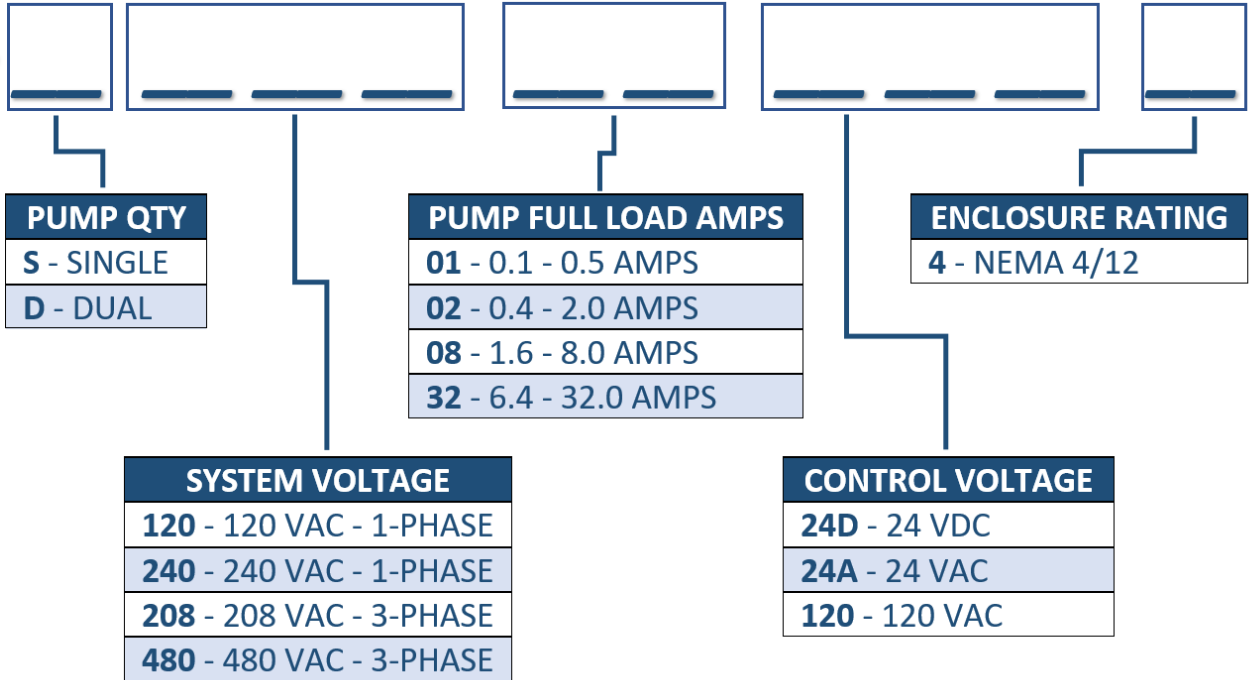

CALL NOW to order
702.340.6264



Power Assemblies, LLC
(702)-364-6264
7061 W. Arby Rd.
Suite 120 Las Vegas, NV
89113



INFO@POWERASSEMBLIES.COM



WWW.POWERASSEMBLIES.COM